

DT9829

USB Multi-sensor Measurement Module *Precision Measurement for All Sensors*

The DT9829 is a portable data acquisition multi-sensor measurement module for USB. The DT9829 supports a universal array of sensor types: voltage inputs, current, thermocouples, RTDs, thermistors, resistance, bridge-based sensors, and strain gages.

Key Features

- **Direct connection** of many types of sensors...**software selectable** per channel
 - **Thermocouples:** B, E, J, K, N, R, S, and T types
 - **RTD:** Pt100, Pt500, Pt1000...2, 3, 4-wire
 - **Thermistors**
 - **Bridge-based sensors:** internal 3.0VDC excitation, +/-200 mV input range
 - **Voltage:** ±10V,±2V,±200mV input range
 - **Current:** ±25mA
 - **Resistance:** 0 to 200kΩ
- **Each input channel independent**...any sensor on any channel, no interaction
- **Sampling to 960Hz**
- **24-bit sigma-delta ADC**...eliminates aliasing for extremely accurate measurement
- **Thermocouple CJC** and open circuit detection
- **4 isolated** digital inputs and digital outputs
- **±500V galvanic isolation**...to PC and ground
- **USB 2.0 powered**...no extra power supply needed
- **Terminal block connections**

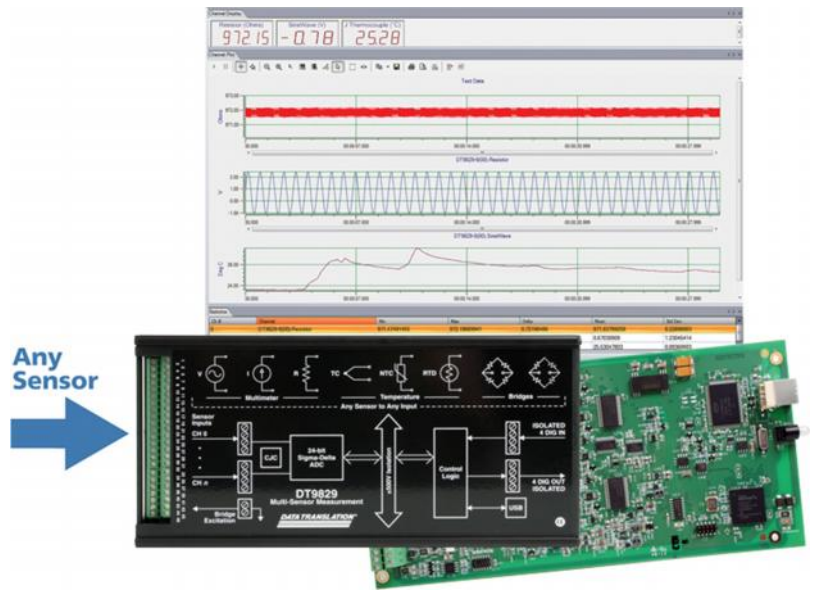

Figure 1. The DT9829 provides up to 8 multi-sensor input channels. Any sensor merely has to be connected at an input and all selections, including any necessary for excitation, cold junction compensation or bridge completion, are included and supported by QuickDAQ. No other circuitry or external components are necessary. OEM model (no enclosure) for embedding is available.

Parameter	Sensor	Feature	Accuracy
Temperature	Thermocouple (B, E, J, K, N, R, S,T)	CJC included	±0.10°C (J)
	RTD (Pt100, 500, 1000)	425 µA Excitation 2-, 3-, and 4-wire connections Callendar Van-Dusen transfer function	±0.03° C
	Thermistor (NTC)	2252Ω to 100 kΩ 2-, 3-, and 4-wire connections Steinhart-Hart transfer function	±0.005° C
Strain, Weight, Torque, Pressure	Load cell, strain gage, general-purpose bridge	Quarter-bridge, Half-bridge, Full-bridge 120 Ω minimum bridge resistance	±0.05% of reading
Electrical	Voltage	±10 V,±2 V, ±200 mV	±0.02% of reading
	Current	±25 mA	±0.1% of reading
	Resistance	0 to 4 kΩ or 4 kΩ to 200 kΩ 2-, 3-, and 4-wire connections	±0.02% of reading

Figure 2. Any sensor above can be connected to any input of the DT9829 for precise measurement of its value. All necessary elements for the sensor are enabled through software selection.

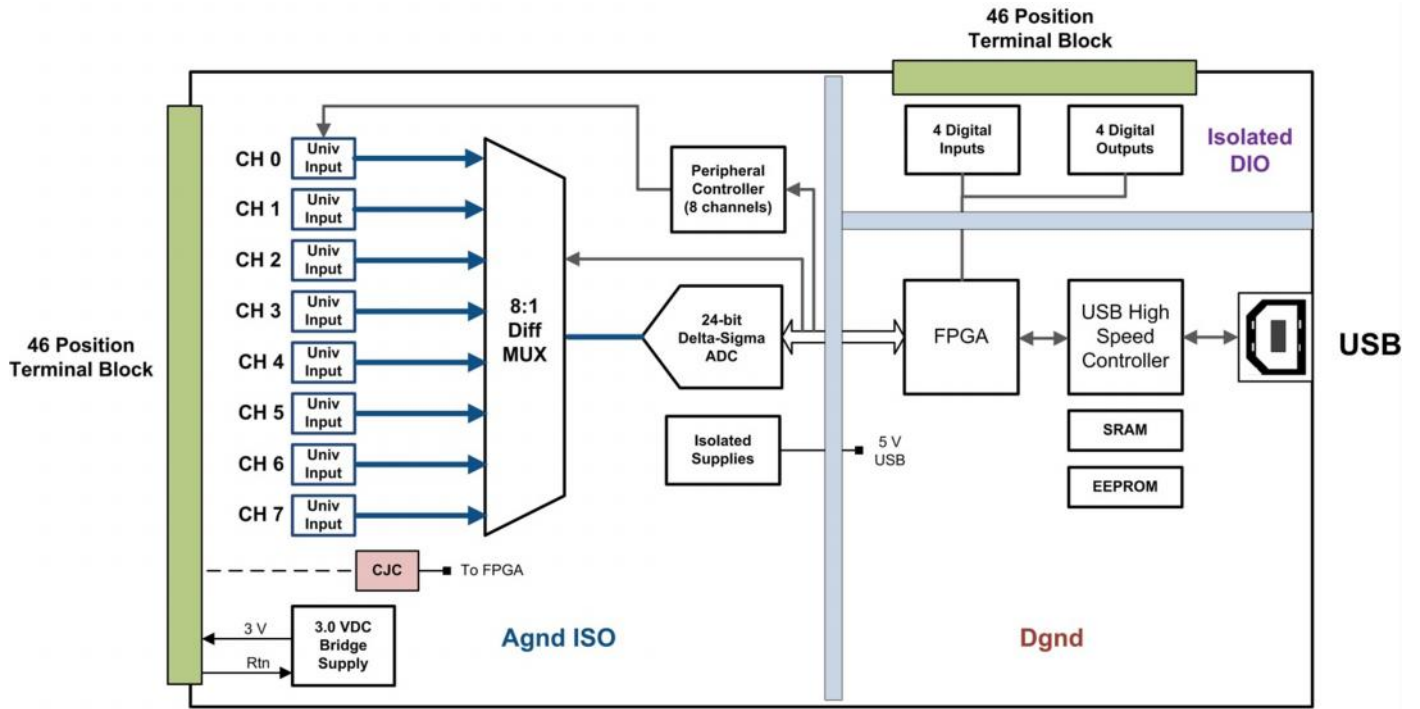
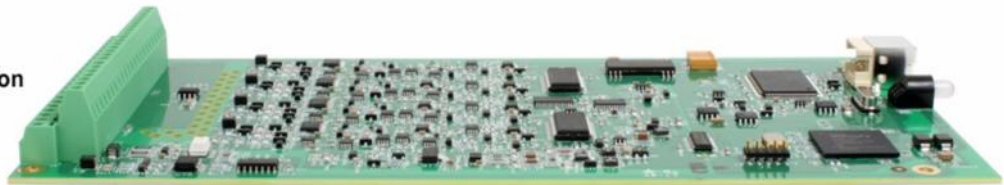

Figure 3. Block diagram of the DT9829 shows that up to 8 sensors of any type can be connected for precision measurement. Applications in industry, lab, or field can take advantage of the portable operation running off USB power.

Faceplate
Includes connection diagram



OEM Embedded Version
DT9829 board



CE-Compliant Enclosure
Maintains signal integrity



Figure 4. Exploded View. The DT9829 case packages the OEM embedded version of the DT9829 in a CE-compliant enclosure.

DT9829

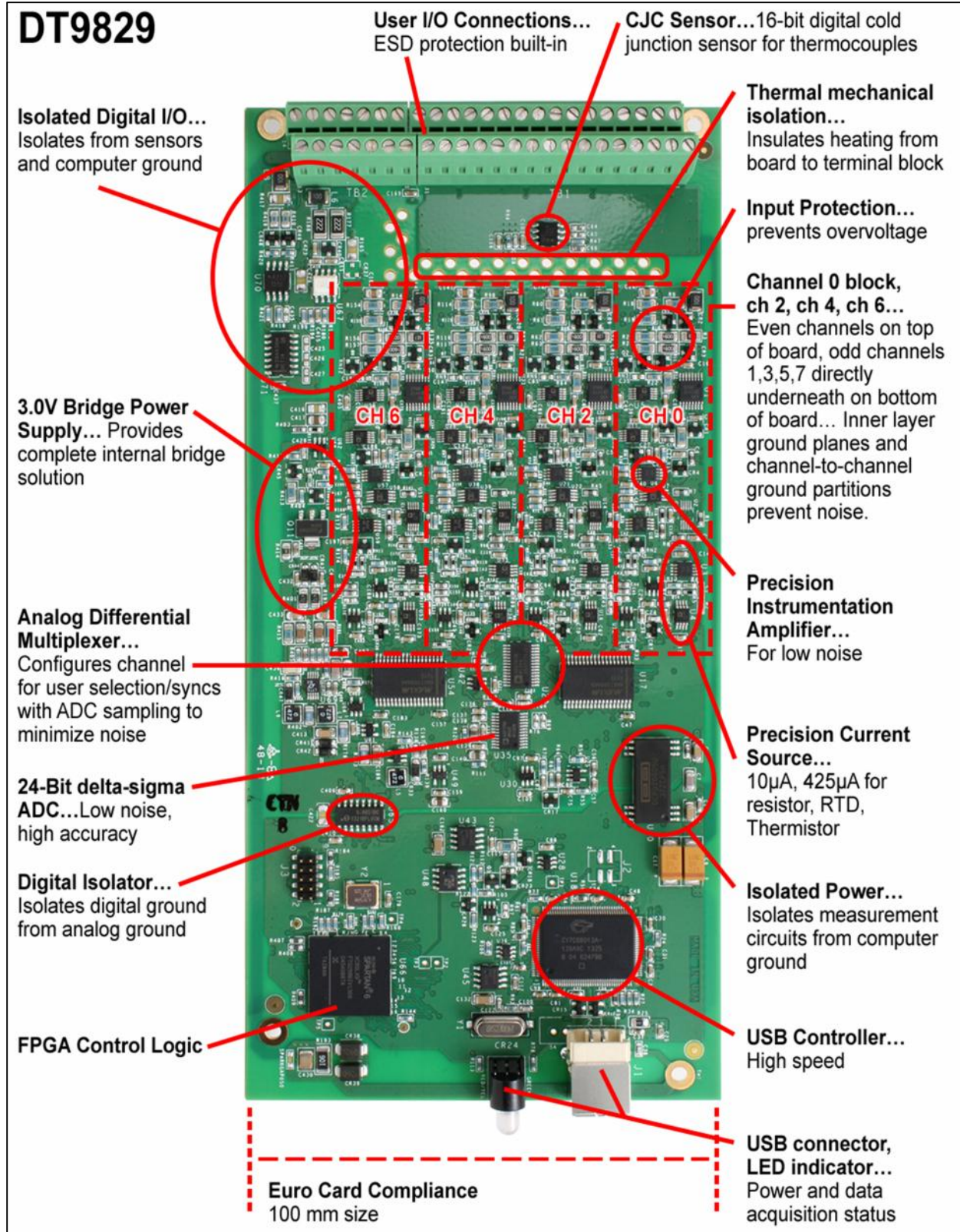

Figure 5. Every design factor is presented to show the uncompromised, high-integrity performance built into the OEM embedded version.

Overview

Any sensor type can be connected to any of 8 screw terminal inputs and the QuickDAQ application software allows selection of the sensor. The software and hardware act seamlessly to make all measurements of the sensor without ANY other user interaction.

The result is the ability to measure any sensor on any of up to 8 channels via software selection. All the messy details are taken care of by the software and the hardware inside the module. There is no interaction between channels, regardless of the sensor type for any channel.

Accuracies have been meticulously designed to preserve the integrity of the sensor measurement. For example, thermocouples have built-in cold junction compensation circuitry that is positioned right at the connector to prevent air flow or error sources in the connection. An additional example is the ability to perform 2, 3, or 4 wire resistor, thermistor or RTD measurements on any channel. Further, the design includes automatic compensation for the errors normally incurred from lead wire resistance in the commonly used 3-wire configuration.

Analog Input Channels

The DT9829 supports up to 8 differential analog input channels that are multiplexed to a single 24-bit Delta-Sigma A/D converter on the module, providing outstanding accuracy.

Each analog input channel can accept any one of the following sensor types: voltage, current, thermocouple, RTD, resistance, thermistor, bridge-based sensors, or strain gage. Channel configuration is done completely through software, making set-up simple.

Voltage Input Support

The DT9829 is versatile enough to support three effective input ranges for measuring voltage signals: +/-10 V, +/-2 V, and +/-200mV. Using software, the user specifies a gain of 1, 5, or 50 to achieve a range of $\pm 10V$, $\pm 2V$, or $\pm 200mV$, respectively.

Floating and grounded signal sources can be wired to screw terminals on the module to preserve signal integrity.

Current Measurement

Measurement of current output devices up to a range of ± 25 mA are supported by the DT9829. The hardware switches in a precision resistor across the terminals of the channel to measure the current source.

Thermocouple Measurement

The DT9829 supports J, K, T, B, E, N, R, and S thermocouple types. All eight input channels are tied to a single CJC to provide highly accurate and consistent temperature measurements.

RTD Measurement

The DT9829 module supports Platinum 100 Ω , 500 Ω , and 1000 Ω RTDs. The resistance of the RTD circuit increases gradually and repeatably with temperature in a non-linear fashion. Measured resistance is then converted to temperature using the Callendar Van Dusen transfer function. Using software, the user specifies the coefficients that are used by this transfer function.

The module provides 425 μA of excitation for RTD inputs. Two-wire, three-wire, and four-wire connection schemes are supported using screw terminals on the module.

Resistance Measurement

For resistance measurements, the DT9829 module supports measurement ranges of 0 to 4k Ω or 4k Ω to 200k Ω . The module provides a 425 μA current source for the 0 to 4 k Ω range and a 10 μA current source for the 4k Ω to 200k Ω range.

The module measures the voltage produced across a connected resistor when the appropriate current source is applied to determine resistance.

Thermistor Measurement

The DT9829 supports Negative Temperature Coefficient (NTC) thermistors with a resistor value of 2252 Ω to 100k Ω at 25 degrees C. The resistance of NTC thermistors increases with decreasing temperature. The typical usable measurement range is -100 to 325 degrees C. The DT9829 module can read a maximum resistance of 200k Ω .

Resistance is converted to temperature using the Steinhart-Hart transfer function. The user specifies the coefficients used by this transfer function in software.

Two-wire, three-wire, and four-wire connection schemes are supported using the screw terminals on the module.

Bridge and Strain Gage Measurement

The DT9829 supports a full range of bridge-based sensors and strain gages, and provides 3.0V of bridge excitation for powering the bridge or strain gage.

For bridge-based sensors, the DT9829 supports transducers, such as load cells, as well as general-purpose quarter-bridge, half-bridge, and full-bridge configurations.

The DT9829 also supports the following strain gage configurations:

- Quarter-Bridge
- Quarter-Bridge Temp Comp
- Half-Bridge Poisson
- Half-Bridge Bending
- Full-Bridge Bending
- Full-Bridge Bending Poisson
- Full-Bridge Axial Poisson

Powerful software included with the module allows the user to specify the bridge configuration, including the gage factor, lead wire resistance, Poisson ratio, and nominal gage resistance.

Clocks and Triggers

The DT9829 uses an internal A/D sample clock to pace analog input operations and a software trigger to start acquisition. This allows for ultimate flexibility in designing your system. The module provides a maximum throughput rate of 960 samples/second.

Isolated Digital I/O

The DT9829 features four, isolated, TTL, 12V and 24V compatible digital input lines and four, isolated, open-collector digital output lines. The DT9829 can read the value of the digital input port in the analog input data stream, perfect for synchronizing analog input measurements with digital events.

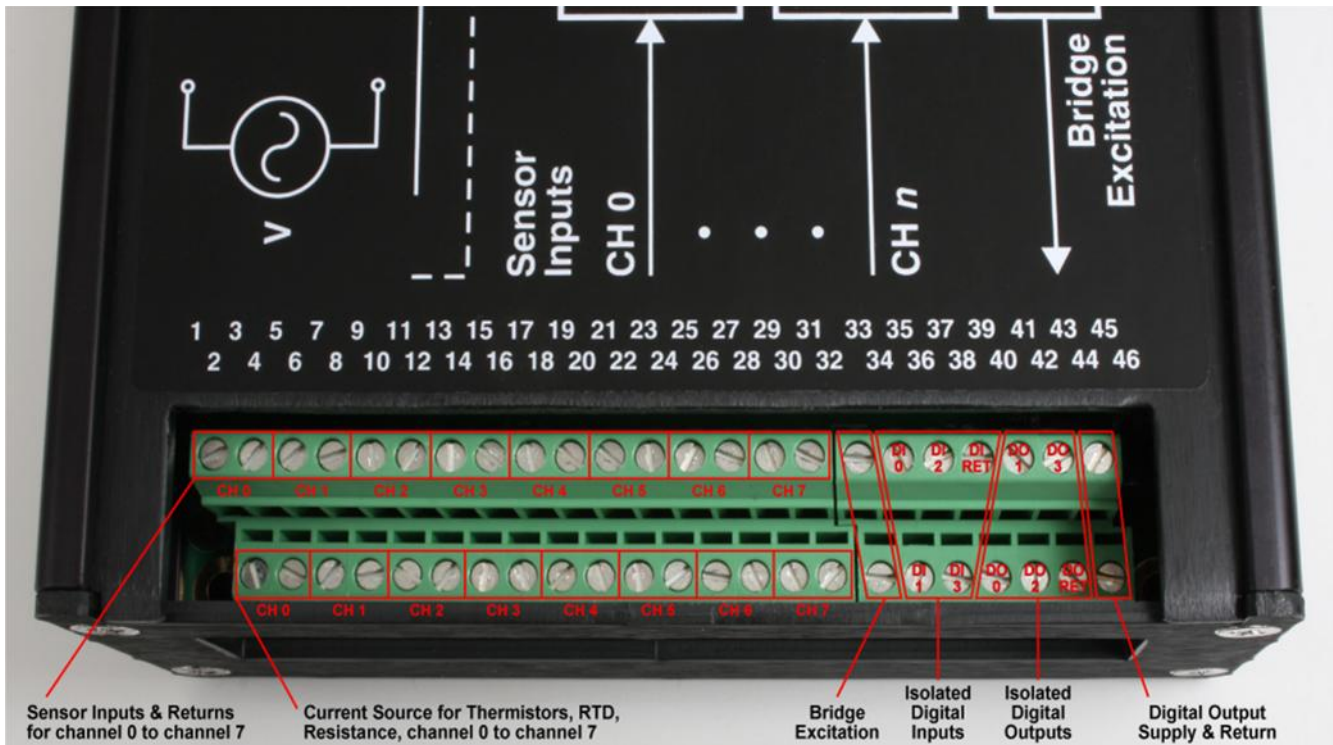

Figure 6. Input connections are easily made via screw terminals for all sensor inputs.

Combining Analog and Digital Input Data In One Stream

Shown below is the timing for a channel gain list consisting of 5 analog input channels and the digital input port. Note that the digital input port may be read as a single-value operation or as part of the analog input stream, as it is in this example. With the module set to the maximum throughput rate of 960 samples/second, the resulting per channel data rate is 160 samples/second.

$$\text{Throughput} = 960 \text{ S/s}$$

$$\frac{\text{Throughput}}{\# \text{ of Channels}} = \frac{960 \text{ S/s}}{6} = 160 \text{ S/s}$$

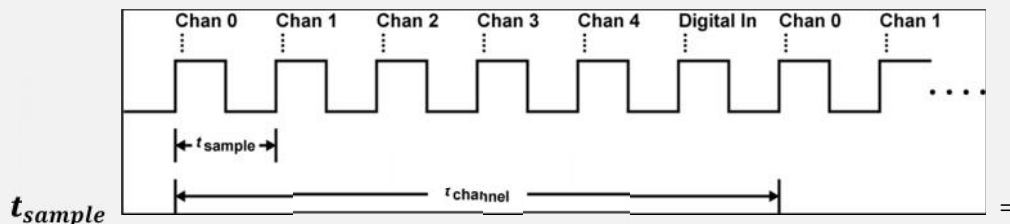

$$\frac{1}{\text{Throughput, Sps}} = \frac{1}{960 \text{ Sps}} = 1.04 \text{ msec}$$

$$t_{\text{channel}} = \frac{1}{\text{Channel Data Rate Sps}} = \frac{1}{160 \text{ Sps}} = 6.25 \text{ msec}$$

QuickDAQ Application Software



Figure 7. QuickDAQ ships free-of-charge and allows you to get up and running quickly.

QuickDAQ allows you to acquire and display from all Data Translation USB and Ethernet data acquisition devices that support analog input streaming. Combine QuickDAQ with the DT9829 to acquire data, record data to disk, display the results in both a plot and digital display, and read a recorded data file. Data can be exported to other applications like Microsoft Excel® and The Mathworks MATLAB® for more advanced analysis. Two additional options can be purchased to add FFT analysis capabilities to the base package.

Key Features

- **QuickDAQ Base Package (Free)**
 - Ready-to-measure application software
 - Configure, acquire, log, display, and analyze your data
 - Customize many aspects of the acquisition, display, and recording functions to suit your needs
- **FFT Analysis Option (License Required)**
 - Includes all the features of the QuickDAQ Base Package and allows you to perform single-channel FFT operations.

- **Advanced FFT Analysis Option (License Required)**
 - Includes all the features of the QuickDAQ Base and FFT Analysis Packages and allows you to perform 2-channel FFT operations.

Other Software

The following software is available for use with the DT9829 and is provided on the Data Acquisition Omni CD:

- **DT9829 Device Driver** – The device driver allows you to use the DT9829 with any of the supported software packages and utilities.
- **DT9829 Calibration Utility** – This utility allows you to calibrate features of the DT9829
- **DAQ Adaptor for MATLAB®** – Provides the interface between the MATLAB Data Acquisition (DAQ) Toolbox from The MathWorks™ and DT-Open Layers architecture.
- **LV-Link** – A library of VIs that enable LabVIEW™ programmers to access the data acquisition features of DT-Open Layers compliant USB and PCI devices.
- **DT-Open Layers® for .NET Class Library**
- **Data Acq SDK**

Ordering Summary

DT9829

- **DT9829-2** 2-channel USB module, with Enclosure
- **DT9829-2-OEM** 2-channel USB module, No Enclosure
- **DT9829-4** 4-channel USB module, with Enclosure
- **DT9829-4-OEM** 4-channel USB module, No Enclosure
- **DT9829-8** 8-channel USB module, with Enclosure
- **DT9829-8-OEM** 8-channel USB module, No Enclosure

Accessories

- **DIN RAIL Kit**

FREE SOFTWARE

- **QuickDAQ**
- **DAQ Adaptor for MATLAB** — Access the analysis and visualization tools of MATLAB®.
- **LV-Link** — Access the power of Data Translation boards through LabVIEW™.

OPTIONAL SOFTWARE

- **QuickDAQ FFT Analysis Option**
(License Required)
- **QuickDAQ Advanced FFT Analysis Option**
(License Required)

All Data Translation hardware products are covered by a 1-year warranty. For pricing information, please visit our website or contact your local reseller.